

## Data sheet

Commercial Art.No.: 55.504.1053.0

Feed-through terminal WKM 4 / 15/V0

Feed-through terminal with Screw connection for mounting on TS 15 , nominal cross section: 4 mm<sup>2</sup>, width: 6 mm, color: grey

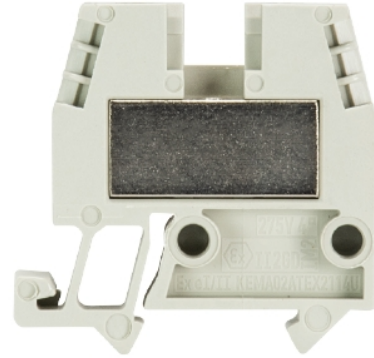

Commercial Art.No.	55.504.1053.0
EAN	4015573478503
Order Unit	100

Certificates / Approvals



**CAN-Ex**



**ATEX**



**USA-Ex**

## Technical data

### General

Nominal cross section	4 mm <sup>2</sup>
Color	Grey
Number of levels	1
Number of clamp positions per level	2
Width/grid dimension	6 mm
Insulating housing	PA666
Inflammability class of insulation material acc. with UL94	V0
Explosion-tested version "Ex e"	yes
Mounting method	DIN rail (top hat rail) 15 mm
Terminal blocks for electrical installations	yes

### Technical data

Rated current	28 A
Rated voltage	500 V
Rated impulse voltage	6 kV
Pollution degree	3
Closing plate required	yes
Type of insulation material	Thermoplastic
Length	32 mm

### Connection Data

Connection type 1	screw connection
-------------------	------------------

Connection type 2	screw connection
Minimum cross section solid	0.5 mm <sup>2</sup>
Maximum cross section solid	6 mm <sup>2</sup>
Minimum cross section fine stranded	0.5 mm <sup>2</sup>
Maximum cross section fine stranded	4 mm <sup>2</sup>
Wire strip length	9 mm
Torque conductor mounting	0.5 Nm

#### Technical Data UL/CSA

Cross section UL	22-10 AWG
Voltage UL	600 V
Current factory wiring	30 A
Current field wiring	30 A
Cross section CSA	20-10 AWG
Voltage CSA	600 V
Current CSA	37 A

#### Classification

ECLASS 11	
ECLASS 8.1	27141120
ETIM 7.0	EC000897
ETIM 6.0	EC000897
ETIM 5.0	EC000897
ETIM 4.0	EC000897
ETIM 3.0	EC000897

#### Product compliance

ROHS conformity status	Compliant/Exempted
ROHS exceptions	III-6(c)
REACH-SVHC conformity status	Duty-To-Declare
REACH-SVHC substances	Lead
REACH-SVHC CAS numbers	7439-92-1

#### Accessories

Commercial Art.No.:	Article-type description:	Description:
Z7.271.2227.0	Insulated jumper bar IVB WK4 E/U- 2	Cross connector, insulated for DIN rail terminal blocks type WK ..., 2 - pole
Z7.271.2327.0	Insulated jumper bar IVB WK4 E/U- 3	Cross connector, insulated for DIN rail terminal blocks type WK ..., 3 - pole
Z7.271.2427.0	Insulated jumper bar IVB WK4 E/U- 4	Cross connector, insulated for DIN rail terminal blocks type WK ..., 4 - pole
Z7.271.2527.0	Insulated jumper bar IVB WK4 E/U- 5	Cross connector, insulated for DIN rail terminal blocks type WK ..., 5 - pole
Z7.271.2627.0	Insulated jumper bar IVB WK4 E/U- 6	Cross connector, insulated for DIN rail terminal blocks type WK ..., 6 - pole
Z7.271.3027.0	Insulated jumper bar IVB WK4 E/U-10	Cross connector, insulated for DIN rail terminal blocks type WK ..., 10 - pole
Z7.271.3227.0	Insulated jumper bar IVB WK4 E/U-12	Cross connector, insulated for DIN rail terminal blocks type WK ..., 12 - pole

98.090.0015.0	Mounting rail TS 15 PERF - l:2000mm	Mounting rail TS 15, slotted, Höhe 5,5 mm, length 2 m, material steel. galv. zinc-plated and dichromated
07.311.0853.0	End plate APM 2,5 - 4 / 15	End plate for DIN rail terminal blocks type WKM 2,5... und WKM 4..., color: grey
07.311.0853.6	End plate APM 2,5 - 4 / 15 BLAU	End plate for DIN rail terminal blocks type WKM 2,5... und WKM 4..., color: blue
07.311.1853.0	Partition TWM 2,5 - 4 /15	Partition for DIN rail terminal blocks type WKM 2,5... and WKM 4..., color: grey

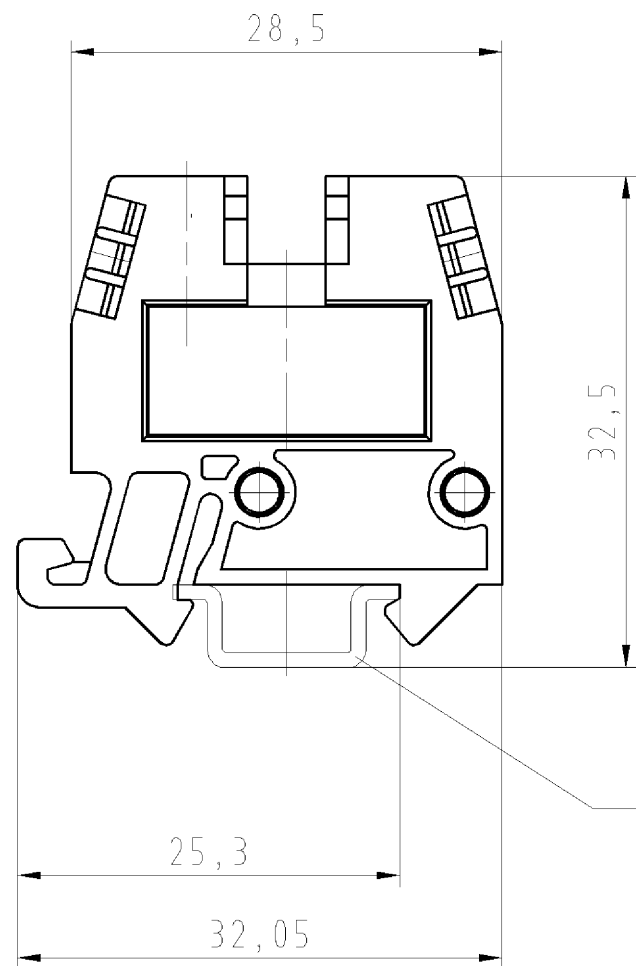

Hutschiene EN 60715-15x5,5  
mountail-rail EN 60715-15x5,5

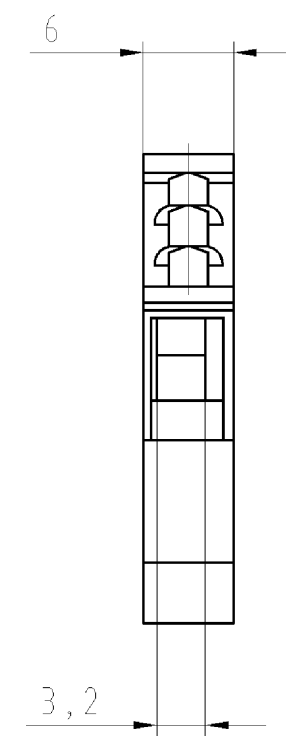
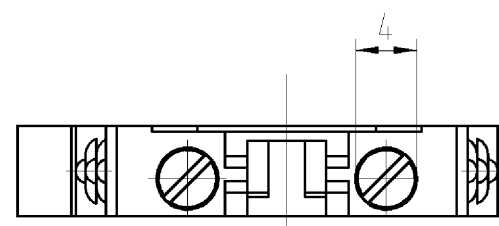

Weitere Daten siehe Katalog  
further data see catalog

Zchnng.-Nr./part-nr.	Farbe/colour	Typ/type
55.504.1053.0	grau/grey	WKM4/15
55.504.1053.1	schwarz/black	WKM4/15 SCHWARZ
55.504.1053.5	rot/red	WKM4/15 ROT
55.504.1053.6	blau/blue	WKM4/15 BLAU
55.504.1053.7	grün/green	WKM4/15 GRÜN
55.504.1053.8	gelb/yellow	WKM4/15 GELB
55.504.1053.9	orange	WKM4/15 ORANGE
55.504.1095.0	grau/grey	WKM4/15

○ Diese Maße werden bei Abnahme besonders geprüft  
○ Ausschließlich Prüfmaße  
○ Mit /E gekennzeichnete Maße sind nur für interne Zwecke gültig

Freitoleranz nach DIN		CAD - Zeichnung, keine manuellen Änderungen			1. Verwendung: -		Bl.: 1 von 1		
	/	Maßstab	2003	Tag	Name	T	Zeichnung Nr.		
	/		Entworfen	30.04.	Schnitt		55.504.1053.0 01K		Index
	/		Geprüft	-	-				a
	/	a	Normgepr.	-	-	Ersatz für: -			
	/		Benennung		DURCHGANGSKLEMME				
Buchstabe Datum / Blatt		Änderung		<b>wieland</b> Elektrische Verbindungen		terminal			

Weitergabe sowie Vervielfältigung dieses Dokuments, Verwertung und Mitteilung seines Inhalts sind verboten, soweit nicht ausdrücklich gestattet. The reproduction, distribution and utilization of this document as well as the communication of its contents to others without express authorization is prohibited.