

## Safety Solution

# SENSOR PRO **SIN M**

## SAFETY SWITCHES WITH SEPARATE ACTUATOR AND GUARD LOCKING



### APPLICATIONS

- Personnel protection on machines with dangerous machine parts which move after switching off
- Locking of a machine or an automatic process when the guard is open
- Position monitoring of guard and guard locking

### FEATURES

- Robust design due to metal rotating head
- Suitable for locking devices in accordance with EN 14119
- Screw connection or M12 connection
- Integrated protection against simple bypassing
- Long service life thanks to dust and water-proof housing and a broad operating temperature range up to 70°C
- Locking force 1,500 N
- Optionally with emergency and escape release

### FUNCTION

The mechanical safety switches in the SIN series are suitable for the secure locking (guard locking) of safety doors until a hazardous machine process has ended.

The safety switches have two independent contact blocks which reflect the position of the actuator on the one hand and the position of the guard locking on the other.

### SPRING-ACTUATED LOCKING

The safety switch on the guard is locked automatically when the actuator reaches its end position.

The guard is unlocked by applying a current to the internal electromagnets in the safety switch.

### MAGNET-ACTUATED LOCKING

The safety switch on the safety guard is locked by energizing the internal electromagnet when the actuator reaches its end position.

If the internal electromagnet is de-energized, the guard control is unlocked and the guard can be opened.

The release of the entry or the shutdown of the machine in case of danger is done by the evaluation of the contact blocks by means of a suitable basic device of the safe RELAY series or one of the safety systems samos® or samos® PRO.

### VERSATILE INSTALLATION

Thanks to the adjustable actuator head and the large selection of actuators, the safety switch can be used to implement guard locking devices for all applications in machine construction.

Universal use through 5 different actuation directions (including from above) and 4 different actuators:

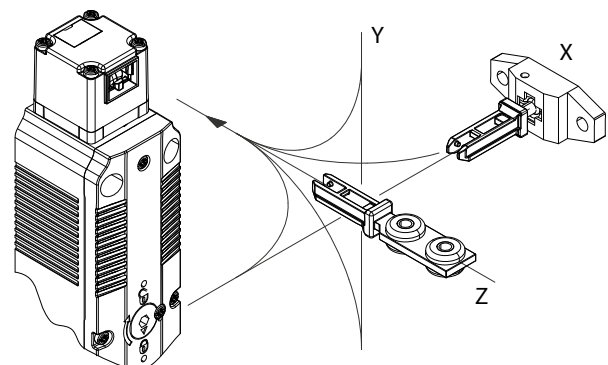

# SIN M SERIES

## SAFETY SWITCH WITH SEPARATE ACTUATOR AND GUARD LOCKING

TECHNICAL DATA	CABLE CONNECTION	M12 CONNECTION
<b>Function</b>		
according to EN 14119	Safety switch with separate actuator and guard locking	
<b>Supply circuit</b>		
Rated voltage	24 V AC/DC	
Continuous output	6.7 VA	
<b>Output circuit</b>		
Contact load conv. thermal current $I_{th}$	5 A	2 A
Application category	AC-15, Ue / Ie 240 V / 1.5 A DC-13, Ue / Ie 24 V / 1.5 A	DC-13, Ue / Ie 24 V / 1.5 A
Mechanical life	1 x 10 <sup>6</sup> switching cycles	
Short-circuit protection	4 A gG	2 A gG
<b>Mechanical data</b>		
Guard locking force	1500 Nm	
Extraction force	> 10 Nm	
Approach speed	max. 0.5 m/s	
Dimensions (L x W x H)	192 x 42 x 44 mm	
Mounting	4 x M5 (tightening moment 2 Nm)	
Cable entry point	M20 x 1.5	-
<b>General data</b>		
Operating ambient temperature	25 °C up to +55 °C	
Wire ranges, push-in terminals	0.34 – 1.5 mm <sup>2</sup> flexibel	
Protection degree according to EN 60529	IP 67	
Standards	EN 60947-5-1, EN ISO 13849-1, EN ISO 14119	
Certificates / approvals	DGUV, c-CSA-us, CCC, UKCA	
<b>Safety-relevant characteristics</b>		
B <sub>100</sub>	2 x 10 <sup>6</sup> cycles	



## SIN M SERIES

### SAFETY SWITCH WITH SEPARATE ACTUATOR AND GUARD LOCKING

#### DIMENSIONS

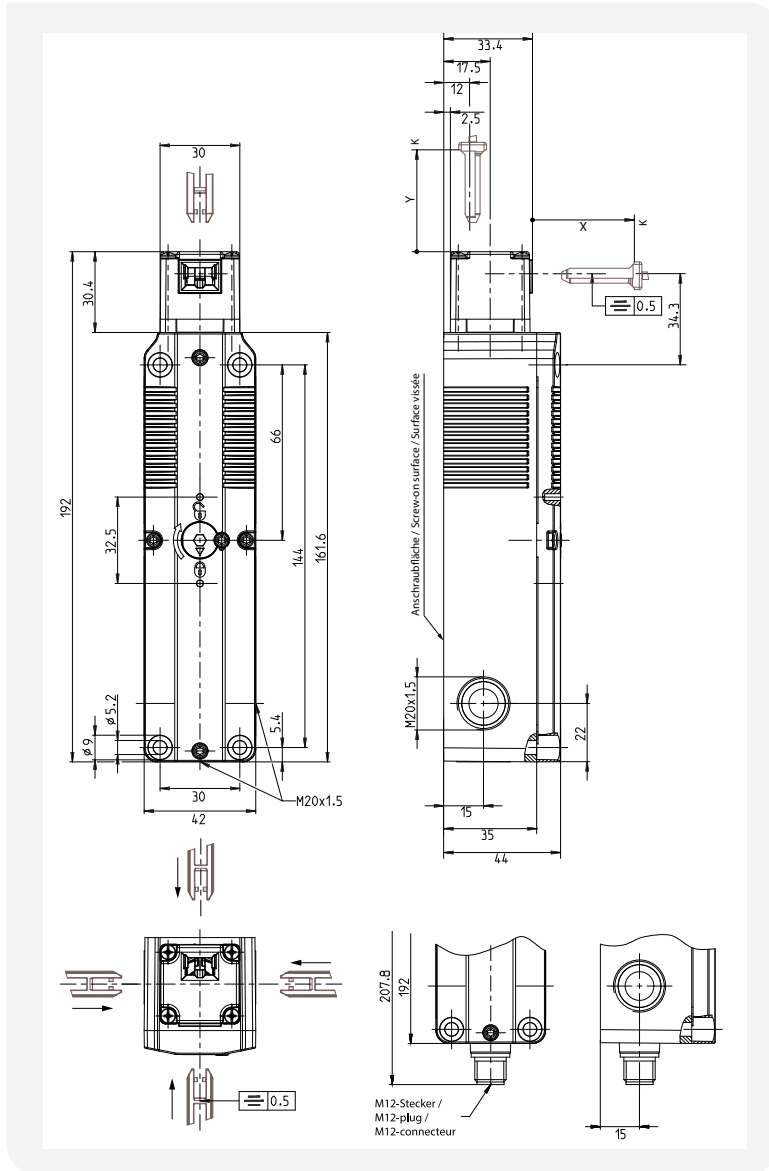

#### OVERVIEW OF DEVICES - SAFETY SWITCH

Type *	Locking principle	Contact assignment (actuator + guard control)	Supply voltage	Other features	Article number	Std. pack
SIN 1150 M	Spring	1NC/1NO+1NC/1NO	24 V AC/DC	Auxiliary release, screw connection	R1.311.1150.0	1
SIN 1120 M	Spring	2NC + 2NC	24 V AC/DC	Auxiliary release, screw connection	R1.311.1120.0	1
SIN 1130 M	Spring	2NC + 1NC/1NO	24 V AC/DC	Auxiliary release, screw connection	R1.311.1130.0	1
SIN 1140 M	Spring	3NC + 1NO	24 V AC/DC	Auxiliary release, screw connection	R1.311.1140.0	1
SIN 1161 M	Spring	1NC + 2NC	24 V AC/DC	Auxiliary release, M12 connection	R1.311.1161.0	1
SIN 2130 M	Magnet	2NC + 1NC/1NO	24 V AC/DC	Auxiliary release, screw connection	R1.311.2130.0	1
SIN 2120 M	Magnet	2NC + 2NC	24 V AC/DC	Auxiliary release, screw connection	R1.311.2120.0	1
SIN 2161 M	Magnet	1NC + 2NC	24 V AC/DC	Auxiliary release, M12 connection	R1.311.2161.0	1
SIN 2140 M	Magnet	3NC + 1NO	24 V AC/DC	Auxiliary release, screw connection	R1.311.2140.0	1

\*the respective actuator must be ordered separately

# SIN M SERIES

## ACTUATOR

### DIMENSIONS

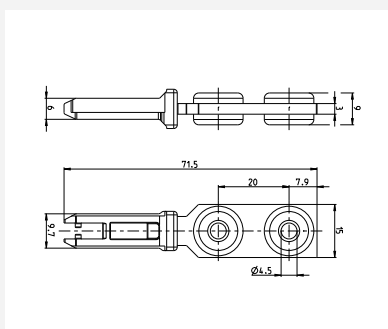

SIN 9001 M

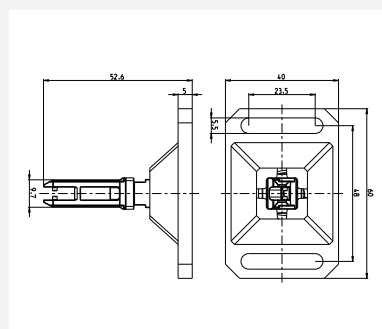

SIN 9002 M

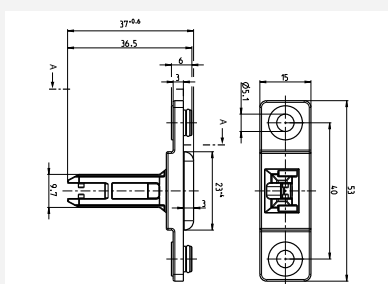

SIN 9003 M

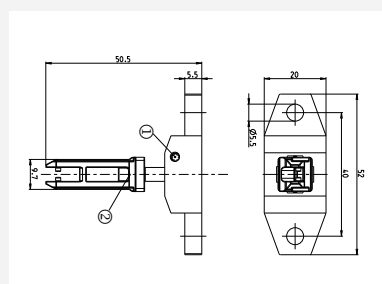

SIN 9004 M

#### APPROACH RADII

SIN 9001 M min > 800 mm

SIN 9003 M min > 600 mm

SIN 9002 M min > 400 mm

SIN 9004 M min > 150 mm

### OVERVIEW OF DEVICES - ACTUATOR + ACCESSORIES

Model	Actuator	Article number	Std. pack
SIN 9001 M	Standard actuator, stainless steel, minimum actuating radius $R_{min}$ 800 mm	R1.311.9001.0	1
SIN 9002 M	Flexible actuator, stainless steel, minimum actuating radius $R_{min}$ 400 mm	R1.311.9002.0	1
SIN 9003 M	Cross actuator, stainless steel, minimum actuating radius $R_{min}$ 600 mm	R1.311.9003.0	1
SIN 9004 M	Radius actuator, stainless steel, minimum actuating radius $R_{min}$ 150 mm	R1.311.9004.0	1
SIN 9005 M	Emergency release front side	R1.311.9005.0	1
SIN 9006 M	Escape release basic set	R1.311.9006.0	1
SIN 9007 M	Extension module for escape release, length 40 mm	R1.311.9007.0	1