

## Control Transformers

## Connect Range Data Sheet Din Rail mounted

Technical data \_\_\_\_\_

Control Transformer	Class 1 Isolation Transformer with Earth Screen between Primary and Secondary
Standard	IEC / BS-EN 61558
Primary Voltages	230 or 400V
Secondary Voltages	One of the following 12, 24, 48, 110, 230V
Frequency	50/60Hz
Insulation Class	B
Insulation Resistance	> 5 Meg $\Omega$
Dielectric Strength	Primary to Secondary. > 2.5kV Primary to Earth > 2.5kV Secondary to Earth > 2.5kV
Ambient Temperature	40° C

### Transformer circuit protection

Transformers must be protected against short circuit and overload

**Primary circuit.** The primary side of the Transformer should be protected against short circuit thereby cutting the supply voltage in the event of a short circuit fault.

The rating of the primary protection device has to take into account the high inrush current during energizing of the Transformer.

The table below gives suggested protection values to avoid nuisance tripping on inrush

Rating VA	Primary Volts	Amps	Fuse	Type C MCB	Type D MCB	Primary Volts	Amps	Fuse	Type C MCB	Type D MCB
25	230	0.108	1	1	1	415	0.06	500mA	1	1
50	230	0.21	1	1	1	415	0.15	500mA	1	1
100	230	0.43	1	2	1	415	0.24	1	1	1

**Secondary circuit.** The secondary circuit should be protected against short circuit and overload. The value of the protection should be the same or less than the rated output current.

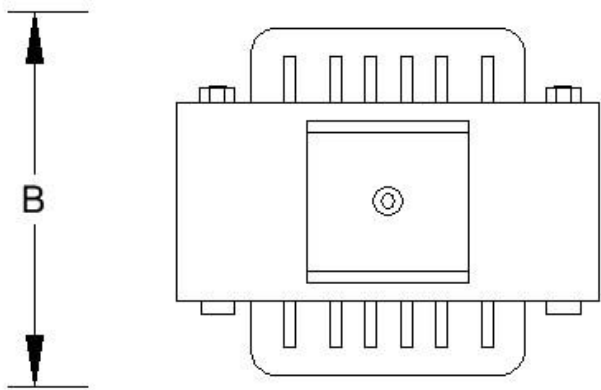
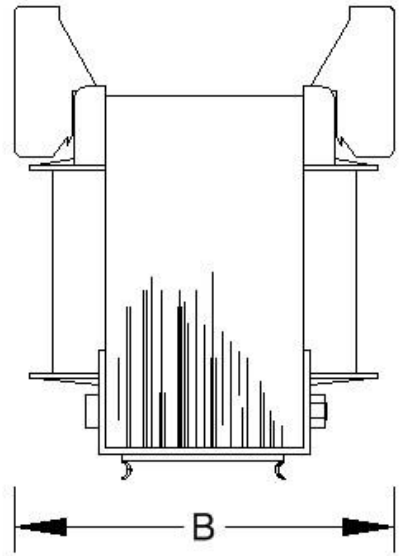
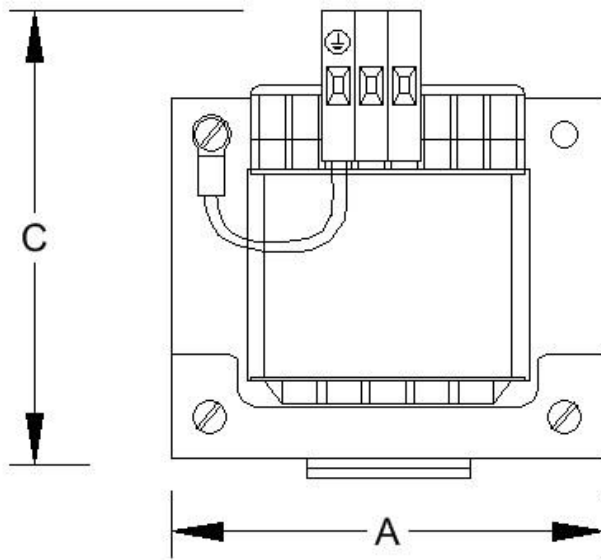

VA	A	B	C	Weight Kg	% Reg.	Watts Loss	Inrush VA For 10% Volt drop	Inrush VA For 5% Volt drop
25	66	68	77	0.7	11	6	48	36
50	76	70	86	1.1	9.8	9	105	77
100	84	78	95	2.1	8.4	14	250	175