

STX Xenon Beacons



Features

- Available in Red, Amber, Green, Blue & Clear
- High 2 Joules 1Hz out put
- Continuously rated
- Weatherproof to IP65
- Easy Installation
- Multi Voltage
- Two mounting options
- 180° Visibility



Part Number

Colour

Voltage

STX-24DA-R	Red	10-28VAC/DC
STX-24DA-A	Amber	10-28VAC/DC
STX-24DA-G	Green	10-28VAC/DC
STX-24DA-B	Blue	10-28VAC/DC
STX-24DA-C	Clear	10-28VAC/DC
STX-230A-R	Red	115-240VAC
STX-230A-A	Amber	115-240VAC
STX-230A-G	Green	115-240VAC
STX-230A-B	Blue	115-240VAC
STX-230A-C	Clear	115-240VAC

STX Xenon Beacons

Dimensions

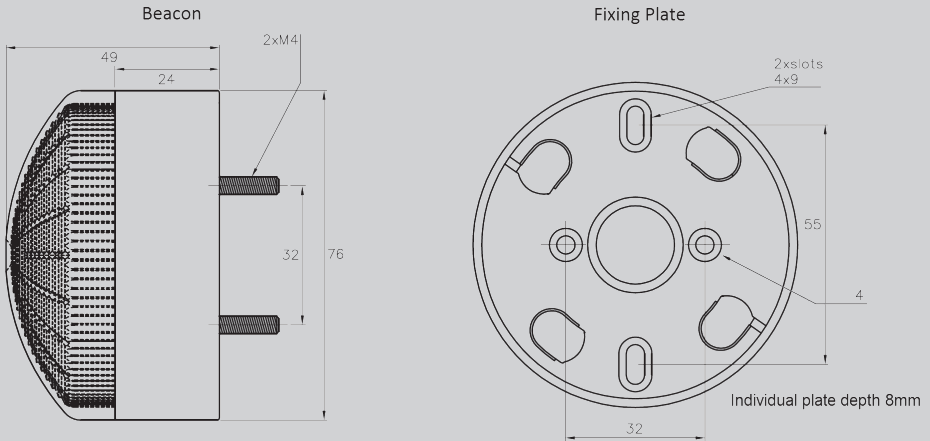

Dimensions in mm

Technical Details

Weight	135g
Temperature	-20 to +55°C
IP Rating	IP 65
Output	1.5-2.5 Joules
Flash Frequency	1 Hz (60 Flashes per Min.)
Visibility	180°
Current	110mA at 24V 52mA at 230V

Installation Details

Panel Mount via 2 x M4 13mm Studs

Surface Mount via 2 Piece fixing plate
2 x Nuts & Washers provided

Wiring

STX-24DA: 2 x 550mm leads. Red wire +ive, Black Wire -ive

STX-230A: 2 x 550mm leads. Brown wire Live, Blue wire Neutral

To maintain IP Rating, ensure sponge gasket is used

Installation

